



Fluxnova

Open Standards, Governed Agents.



Riyaz Patel

BPM Platform Lead
NatWest Group



Pieter Schutte

Principal Engineer
NatWest Group



What to expect

BPM as the foundation

How process orchestration helps enterprises coordinate work across people, systems, services and decisions.

Agentic orchestration in Fluxnova

How we're enabling AI agents to participate inside BPMN processes, without turning the whole process into an AI black box.

MCP capability

How Fluxnova processes can be exposed as reusable capabilities that AI tools and agents can interact with through a standard interface.

What does BPMN bring?

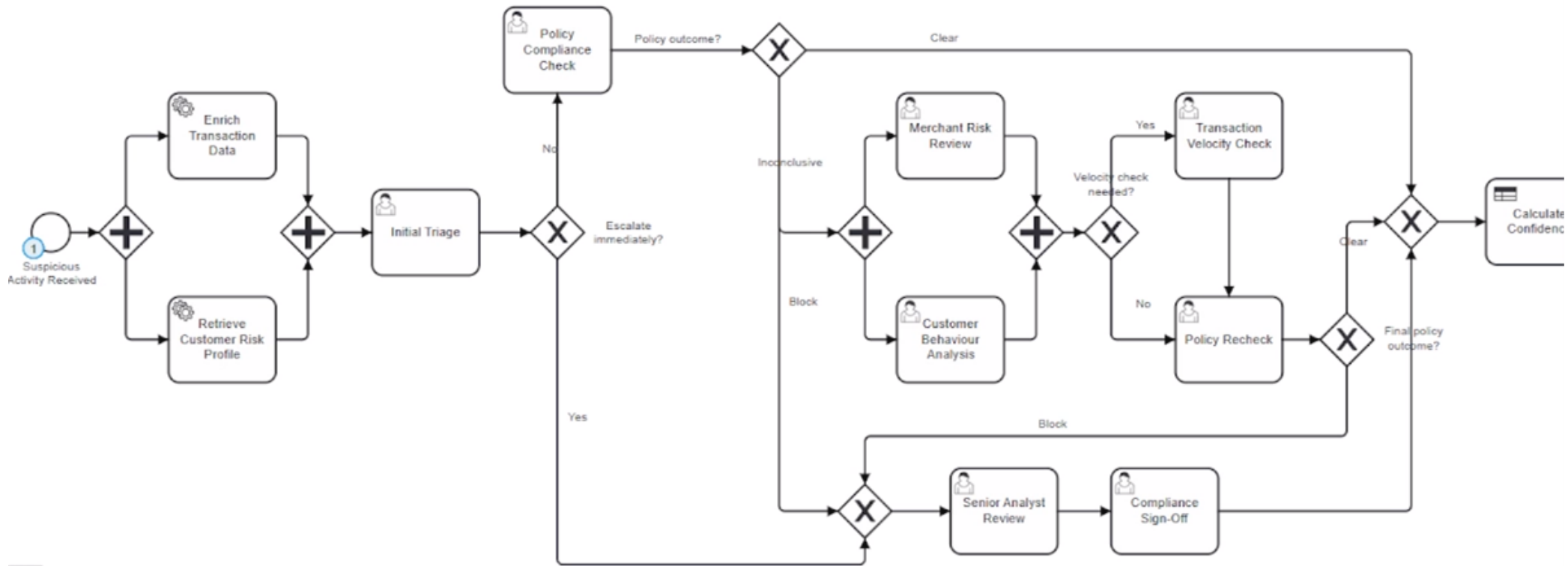

- People
- Systems
- Data
- Services

Control

Auditability

Observability

Governed

Human in the loop

Why this matters today?



What should happen



The process flow,
rules and
outcomes.



Who or what should act



People, systems,
services or
decisions.



Where work is right now



Live status,
progress,
exceptions and
delays.



What happened before

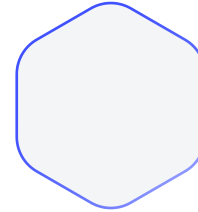

History, audit trail
and evidence.



BPM gives us a familiar place to introduce AI without throwing away enterprise controls

People

Systems

Data

Services

AI / Agents



AI brings.

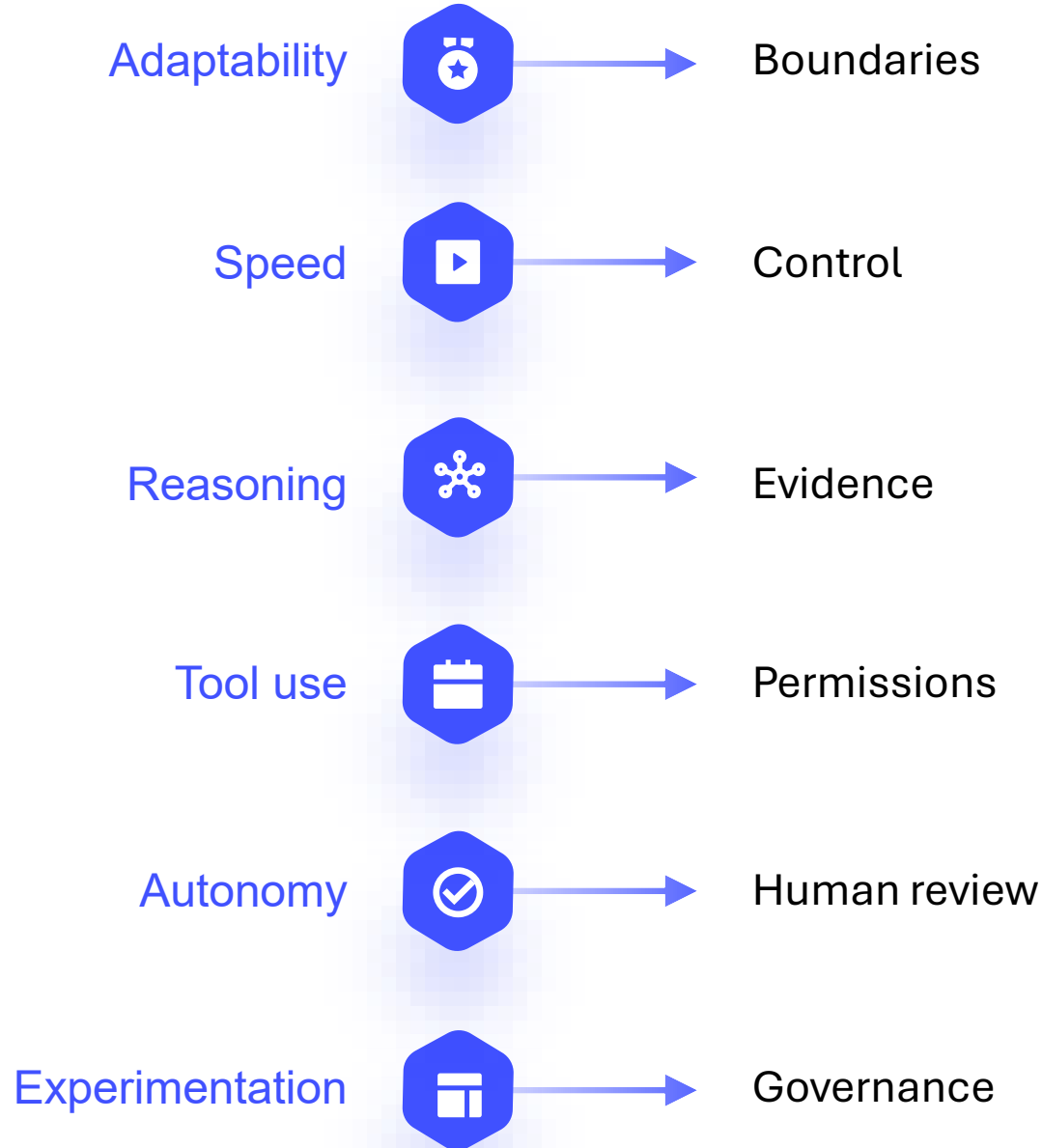

Enterprise
Still Needs.

As AI capabilities become more powerful, the surrounding process becomes more important.

Orchestration in Fluxnova.

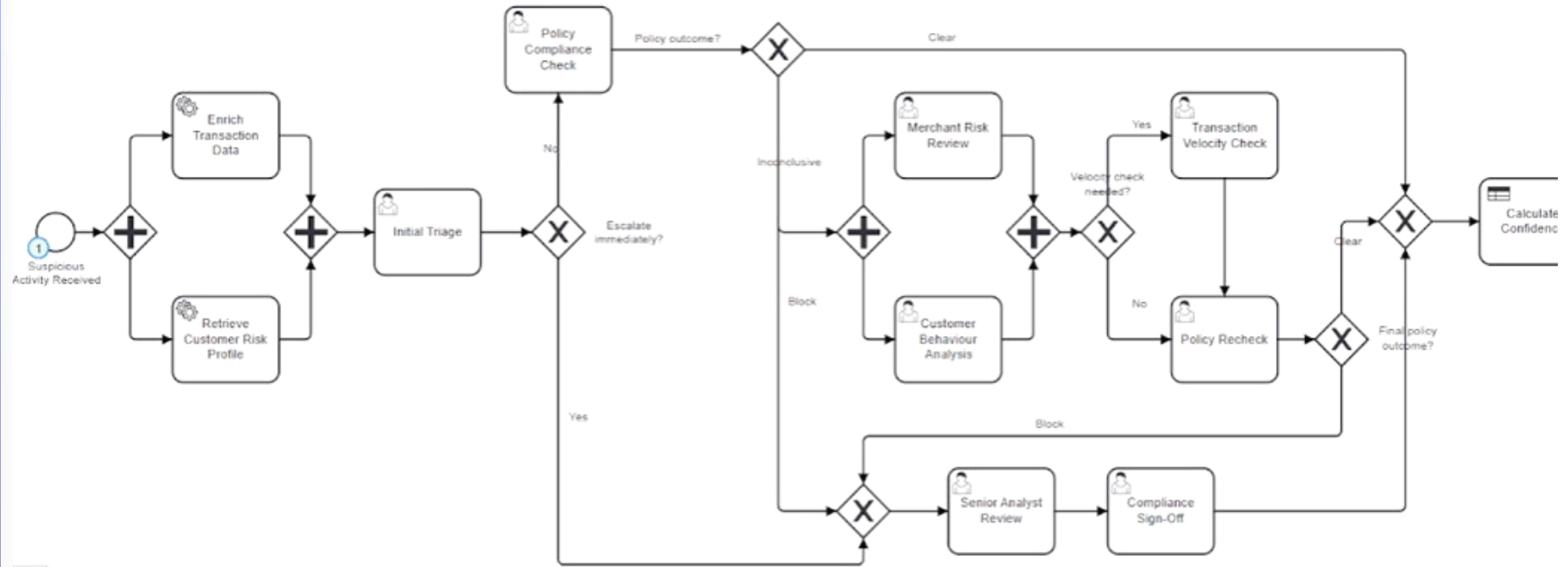

Control

Auditability

Observability

Governed

Human In the loop

Agentic Orchestration in Fluxnova.



Constrained Agent visible in the process

Process Context provided

Connect to a chosen LLM for reasoning

Configured tools

Governed through BPMN

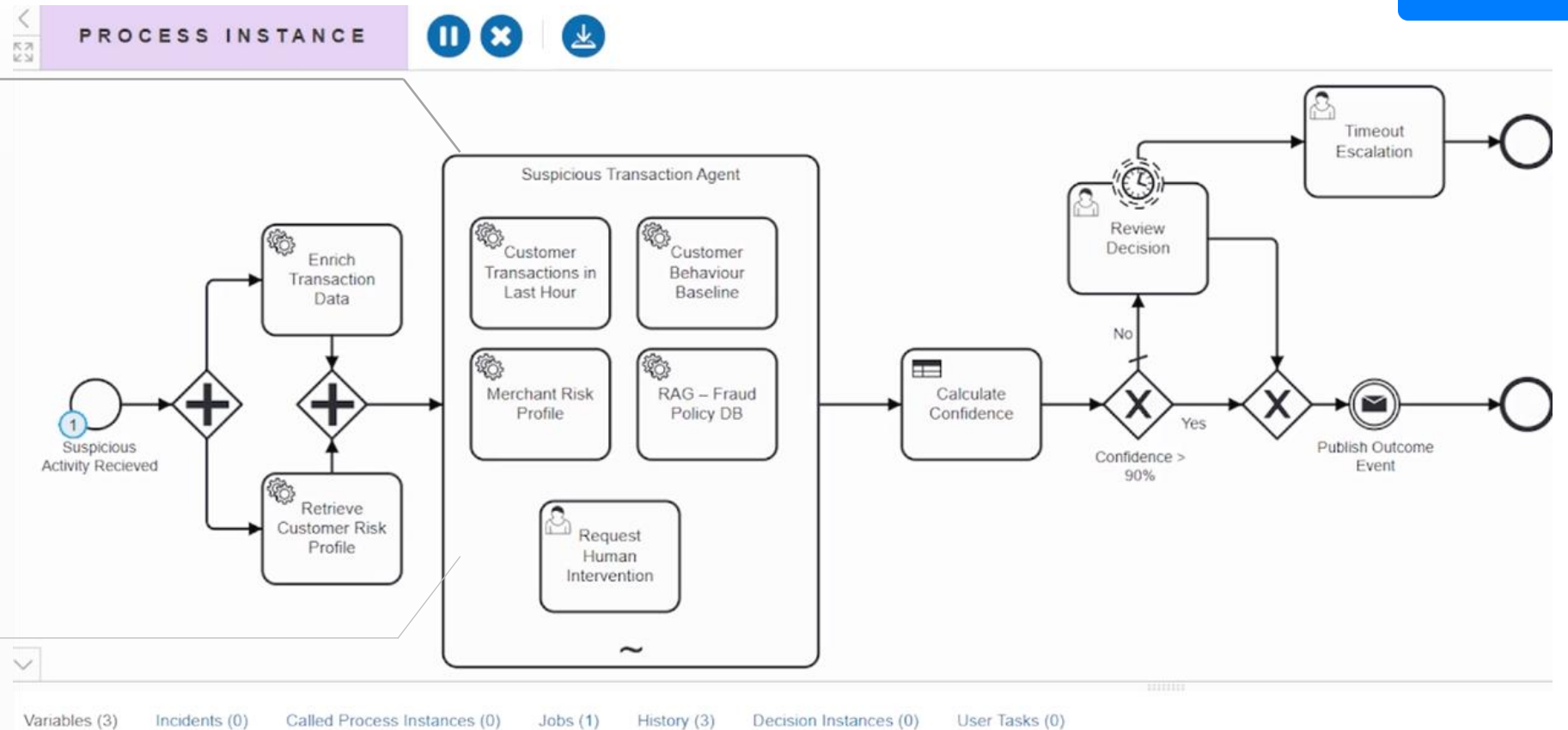

Control

Auditability

Observability

Governed

Human In the loop

Process remains responsible

Visible in Control Centre

Full Audit trail of all AI components

Process Context retained

Agent reasoning recorded

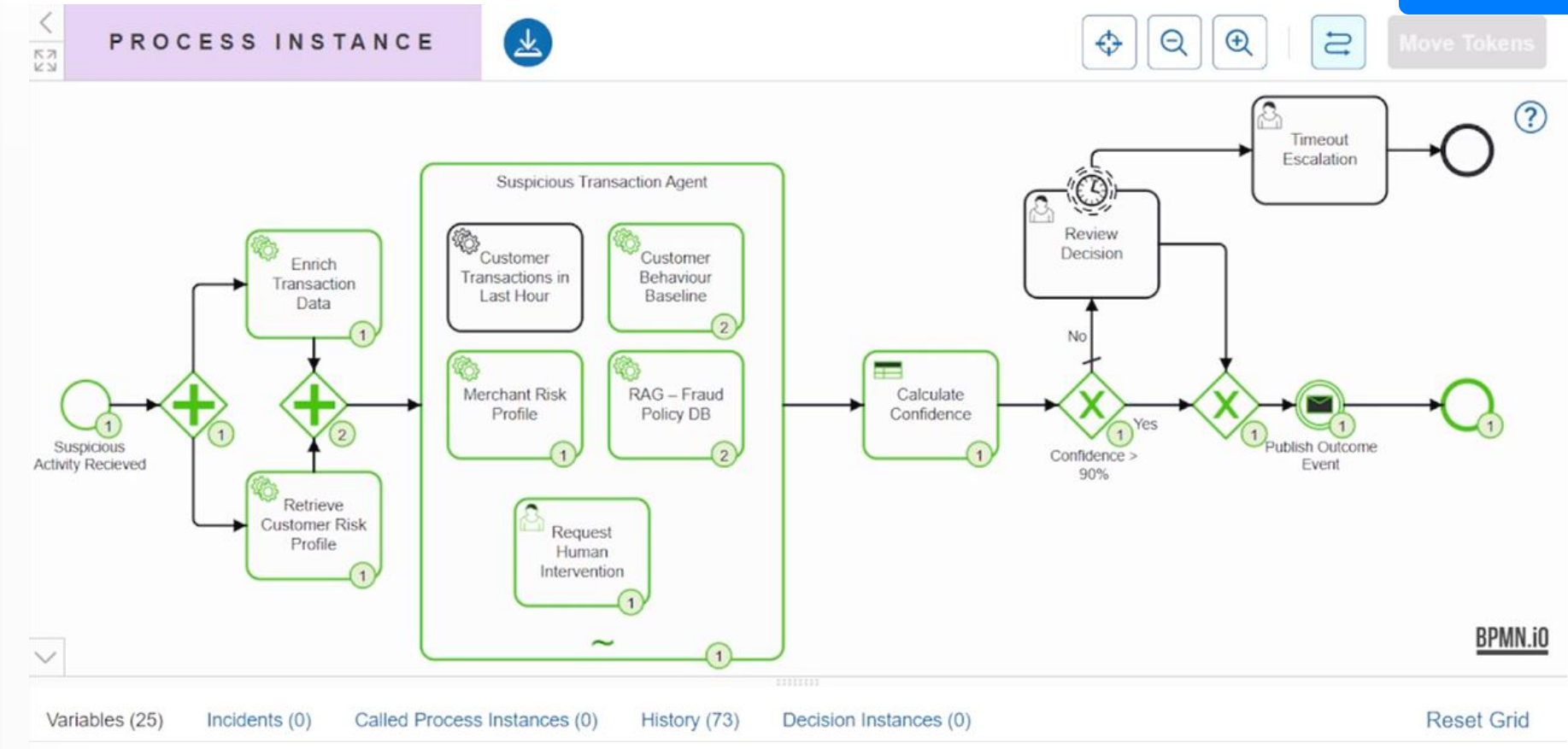

Control

Auditability

Observability

Governed

Human In the loop



MCP.

Processes become **capabilities**

Give AI access to the processes you already **trust**

- ✓ Reuse existing processes and logic
- ✓ Reduce bespoke integration
- ✓ Retain organization controls
- ✓ Connect new AI experiences faster

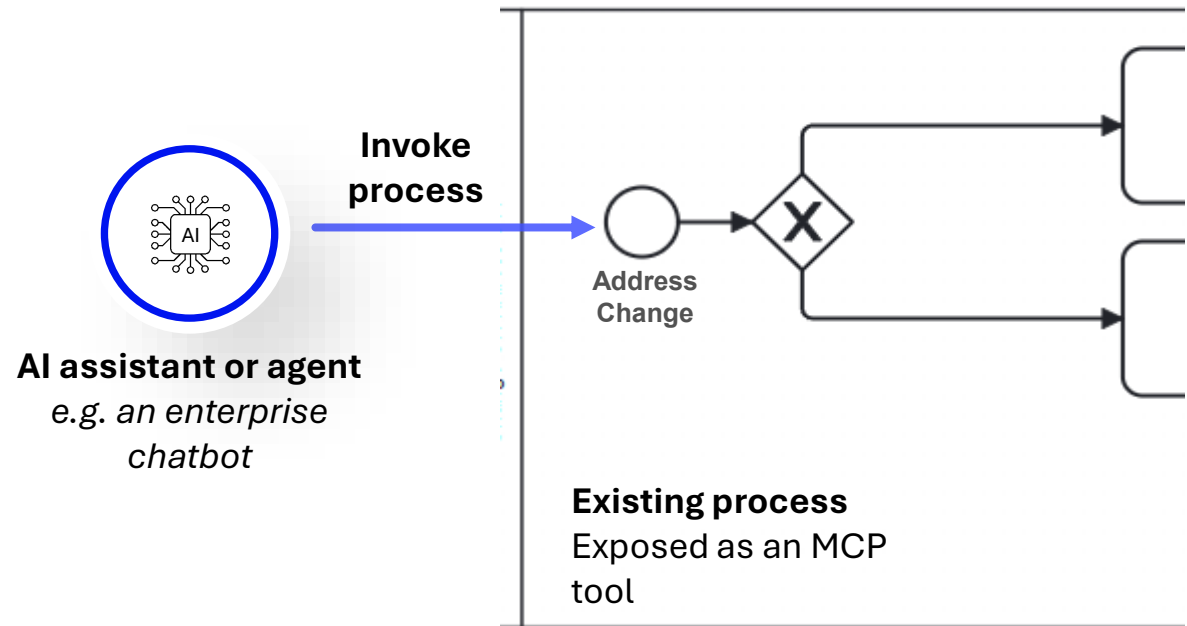
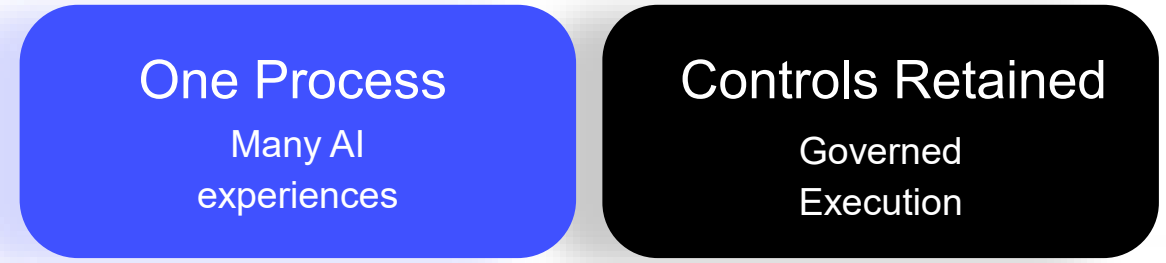



Open Standards

with BPMN at
its core

Shared Capability

without creating
another closed
ecosystem

Enterprise Ready

Agents inside
organisation control

— Fluxnova

Open Platform.
Shared Progress.

Continuing to develop Fluxnova,
evolving for AI-enabled work



— Pieter & Riyaz

Thank You.

Fluxnova maintainers
are available all day.
