

When Your Budget Laptop Needs a Custom Kernel

A Linux Troubleshooting Adventure

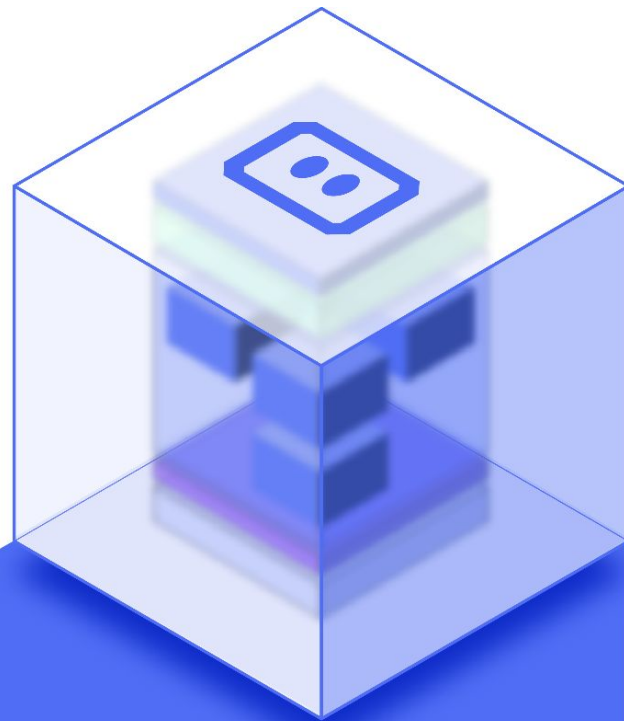

with **Andrei Pokhilko**
CTO Office Dev, Komodor



Description

This talk chronicles my journey of troubleshooting a Linux kernel issue on a budget Intel GeminiLake-based Chinese mini-laptop. What began as a simple hardware purchase escalated into a two-month deep dive into the i915 GPU driver when the display mysteriously went blank during initialization.

I'll walk through the systematic troubleshooting approach: isolating the issue to the i915 driver, identifying the kernel configuration options triggering the problem, and developing a practical patch that bypasses problematic GPIO pin activation sequences. Along the way, I'll share surprising discoveries about hardware compatibility, kernel development complexity, and the limitations of AI tools when facing real-world Linux challenges.

This presentation is designed for Linux enthusiasts and IT professionals curious about kernel troubleshooting. Attendees will leave with practical knowledge about GPU driver internals, confidence that such issues are solvable without specialized expertise, and inspiration to tackle their own hardware compatibility challenges.

Linux Kernel might be scary for the newcomers, even experienced developers. My talk will illustrate how reachable the Kernel is and how persistence and dedication can solve the problem that initially looks as "out of your area of control".

Who's talking?

- Experienced software developer
- Technology innovation researcher
- Desktop Linux user for 15 years



The skills and methods of troubleshooting are my bread and butter.

“Systematic elimination” strategy is key for today’s talk. AKA “Divide and conquer”

Can jealousy be good?

My friend has made himself

A CYBERDECK

now I also want a new toy!



Why you need a mini-laptop?

01 — Work-friendly



02 — Travel-friendly



03 — Night-friendly



04 — Loss-friendly

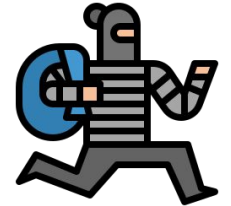

LONGEVINCE 10.1 Inch Mini Laptop

“for School and Work, Lightweight and Portable”

Size: 10.1” (24 x 17.5 x 2 cm)

CPU: 2 core 2.80 GHz (Celeron N4020)

RAM: 8GB

Disk: 256GB SSD

Ports: 2xUSB-A, miniHDMI, microSD, webcam, Wi-Fi

Battery: 2500mAh, USB-C power

OS: Windows 11 Pro

[Amazon.de](https://www.amazon.de)

Price: 250 €



Let's grab it in Germany!

(USB stick with
Xubuntu 24.04 LTE
is in my pocket)





X0026NCY5V

Neu - LONGEVINCE 1... Pro, Type-
(C2566)

MADE IN CHINA

NetBook

10.1inch



UN 3481

GBK/Infotrac ID 110543 (USA domestic) 1 800 535 5053
or International (001) 352 323 3500

Marke: LONGEVINCE
Produktname: Laptop
Modell: N158
Spannung: 12 V
Hersteller: Lianwei Innovation Technology (Shenzhen)
 Co., Ltd
Adresse: Gebäude 401, Jinxing Industrial Park, Jian'an
 Road, Zhancheng Community, Fuhai
Email: smarteu222@gmail.com
Produktspezifikationen und technische Bedingungen:



MADE IN CHINA

CCTI-2024061201-5E

CCT1-2024061201-4E

CCT1-2024061201-3E

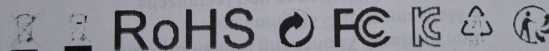

EU

REP

SUCCESS COURIER SL

CALLE RIO TORMES NUM. 1, PLANTA 1, DERECHA,

OFICINA 3, Fuenlabrada, Madrid, 28947 Spain

successservice2@hotmail.com

F1001224521820524pVCF

We simply act as EU representative for cross-border sellers, and are not manufacturers/importers/distributors for the product, nor involved in the manufacture/import/retail of the product. Therefore, we are not responsible for any after-sales services related to the product. In case of any product quality or infringement issues, the manufacturer/importer/seller shall be solely held responsible.



Bitte nicht an einer hohen Stelle platzieren, um Stürze zu vermeiden

Let's put appropriate OS into it!



Mistakes were made

1. Booted into Windows, looks fine for erasing it
2. Ubuntu installer: screen blank, used `nomodeset`
3. **That should have rung the bell! But I continued :(**
4. Boots, but display goes blank. `nomodeset` helps



Christmas markets! Glühwein mit würostchen!

And some tinkering in the evenings...



Troubleshooting is like peeling onion

- Layer after layer
- Often you curse
- Sometimes you cry
- But you have to keep going
- Sometimes with sub-onions inside



Note on ChatGPT (jan 2025)



- Is it hallucinating or the suggestion just don't work?
- Defaults to "X system present" even with explicit restriction
- Googling is hard, my lack of expertise makes it harder
- Chats history is natural journal of this adventure

Trying to fix



X System To Blame?

Easy to validate, just boot into text console:

```
sudo systemctl set-default multi-user.target
```

Hardware problem?

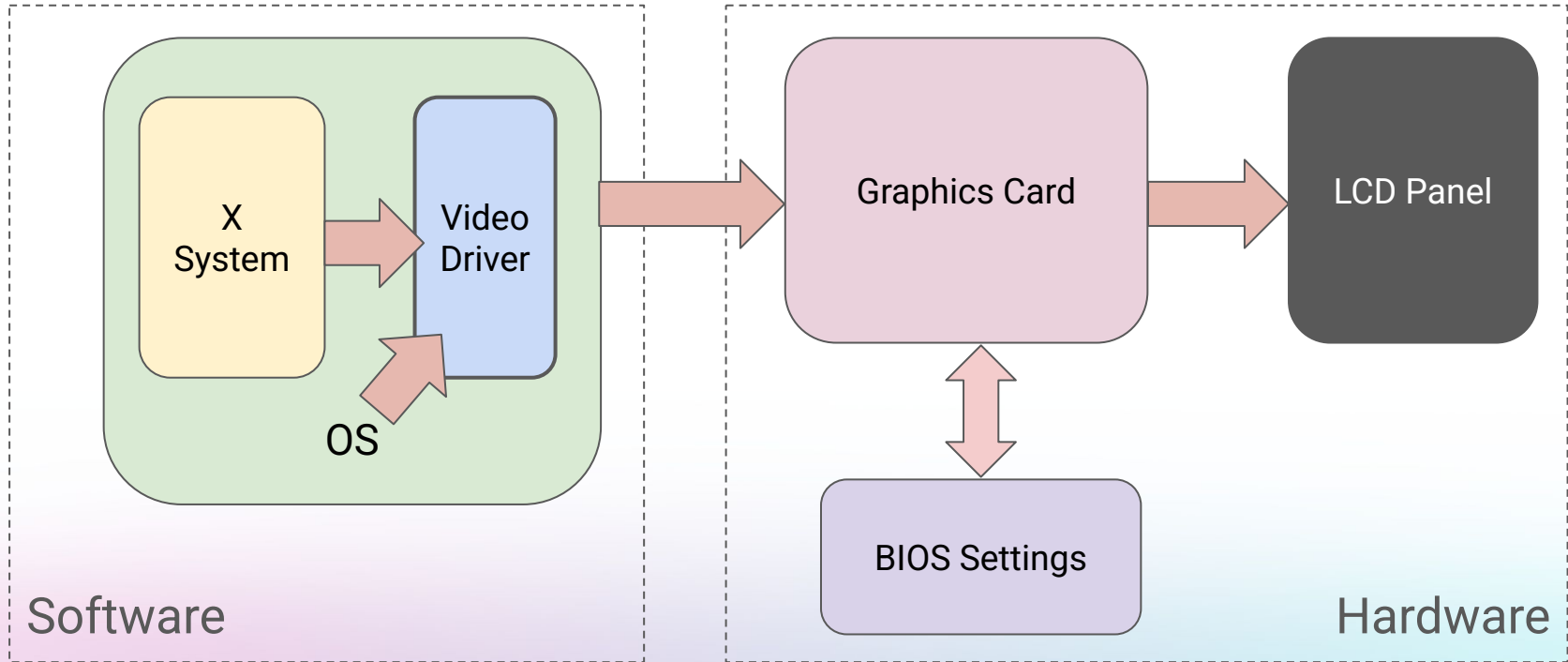

Something in BIOS?

```
Aptio Setup Utility - Copyright (C)
  Chipset

GOP Configuration
GOP Driver           [Enable]
Intel Graphics       [Disable]
Pei Display Peim
GOP Brightness      [60]
Level
VBT Select           [MIPI Auo]

IGD Configuration
Integrated           [Enable]
Graphics Device
Primary Display      [IGD]
RC6(Render Standby) [Enable]
GTT Size             [8MB]
Aperture Size        [256MB]
DVMT                 [256M]
Pre-Allocated
DVMT Total Gfx Mem  [256M]
Cd Clock             [158.4 MHz]
Frequency
GT PM Support        [Disable]
PAVP Enable          [Disable]

IGD - LCD Control
BIA                  [Auto]
ALS Support           [Enable]
IGD Flat Panel       [Auto]
IGD Boot Type        [VGA Port]
Panel Scaling        [Auto]
GMCH BLC Control     [GMBus-Inverted]
```

```
Aptio Setup Utility - Copyright (C)
  Advanced

Intel(R) Graphics Controller
Intel(R) GOP Driver [13.0.1018]
Output Select        [MIPI1]
```

BIOS Reset

Annoying :(

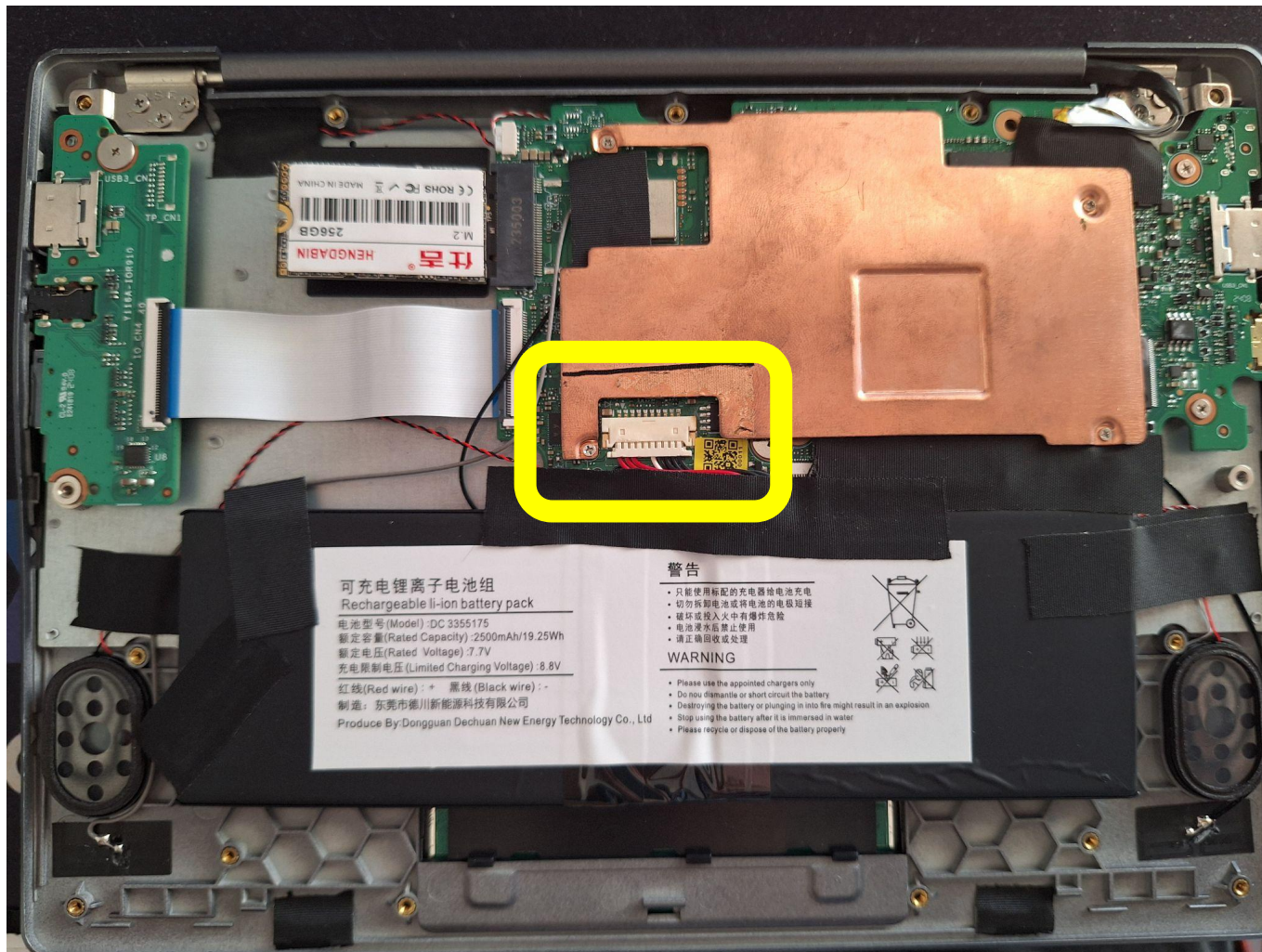

Wrong resolution settings?

```
GRUB_GFXMODE=1024x768 + GRUB_GFXPAYLOAD_LINUX=keep
```

Changing `GRUB_CMDLINE_LINUX_DEFAULT` becomes routine:

- `video=vesafb:1024x768-32`
- `i915.enable_fbc=0 i915.enable_psr=0 i915.modeset=1`
- `drm.debug=0xe log_buf_len=4M ignore_loglevel`

`fbset` command to set it after? No effect

```
sudo fbi -T 1 -d /dev/fb0 ~/picture.jpg - good direct test
```

vga=0x315

Here is a chart of kernel mode numbers for the 'vga=' boot parameter.

Colours	640x400	640x480	800x600	1024x768	1152x864	1280x1024	1400x1050	1600x1200
4 bits	?	?	0x302	?	?	?	?	?
8 bits	0x300	0x301	0x303	0x305	0x161	0x307	?	0x31C
15 bits	?	0x310	0x313	0x316	0x162	0x319	0x340	0x31D
16 bits	?	0x311	0x314	0x317	0x163	0x31A	0x341	0x31E
24 bits	?	0x312	0x315	0x318	?	0x31B	0x342	0x31F
32 bits	?	?	?	?	0x164	?	?	?

GRUB can tell what's supported: **videoinfo**

```
grub> videoinfo
List of supported video modes:
Legend: mask/position=red/green/blue/reserved
Adapter `Bochs PCI Video Driver':
  No info available
Adapter `Cirrus CLGD 5446 PCI Video Driver':
  No info available
Adapter `EFI GOP driver':
* 0x000 800 x 1280 x 32 (3200) Direct color, mask: 8/8/8/8 pos: 16/8/0/24
  0x001 640 x 480 x 32 (2560) Direct color, mask: 8/8/8/8 pos: 16/8/0/24
  0x002 800 x 600 x 32 (3200) Direct color, mask: 8/8/8/8 pos: 16/8/0/24
  EDID version: 1.4
  Preferred mode: 800x1280
grub> _
```

Everything says "resolution is OK"

dmesg

```
[drm] Initialized simpledrm 1.0.0 for simple-framebuffer.0 on minor 0
Console: switching to colour frame buffer device 100x80
simple-framebuffer simple-framebuffer.0: [drm] fb0: simpledrmdrmfb frame buffer device
i915 0000:00:02.0: [drm] Unknown revision 0x06
i915 0000:00:02.0: [drm] Found geminilake (device ID 3185) integrated display version 10.00
i915 0000:00:02.0: [drm] Unknown revid 0x06
Console: switching to colour dummy device 80x25
i915 0000:00:02.0: vgaarb: deactivate vga console
i915 0000:00:02.0: [drm] *ERROR* conflict detected with stolen region: [mem 0x7c000000-0x7fffffff]
i915 0000:00:02.0: [drm] couldn't get memory information
i915 0000:00:02.0: vgaarb: VGA decodes changed: olddecodes=io+mem,decodes=io+mem:owns=io+mem
i915 0000:00:02.0: [drm] Finished loading DMC firmware i915/glk_dmc_ver1_04.bin (v1.4)
i915 0000:00:02.0: [drm] RC6 and powersaving disabled by BIOS
[drm] Initialized i915 1.6.0 for 0000:00:02.0 on minor 1
ACPI: video: Video Device [GFX0] (multi-head: yes rom: no post: no)
input: Video Bus as /devices/LNXSYSTM:00/LNXXSYBUS:00/PNP0A08:00/LNXVIDEO:00/input/input9
fbcon: i915drmfb (fb0) is primary device
Console: switching to colour frame buffer device 100x80
i915 0000:00:02.0: [drm] fb0: i915drmfb frame buffer device
i915 0000:00:02.0: [drm] *ERROR* GPIO index 6 request to set 0 failed (-EPROBE_DEFER)
i915 0000:00:02.0: [drm] *ERROR* GPIO index 6 request to set 1 failed (-EPROBE_DEFER)
i915 0000:00:02.0: [drm] *ERROR* GPIO index 6 request to set 0 failed (-EPROBE_DEFER)
i915 0000:00:02.0: [drm] *ERROR* GPIO index 6 request to set 1 failed (-EPROBE_DEFER)
```

Memory allocation conflict?

ERROR conflict detected with stolen region: [mem 0x7c000000-0x7fffffff]

ChatGPT: memmap=64M\$0x70000000

Laptop: - _ (ツ) _ / -

Intel Driver Issue Tracker

- How to File i915 Bugs
- <https://drm.pages.freedesktop.org/intel-docs/how-to-file-i915-bugs.html>

drm / i915 /  kernel / Issues / #13451

Screen gets blank after boot

Open Issue created 7 months ago by **Andrey Pokhilko**

I have purchased a small Intel-based laptop (<https://www.amazon.de/dp/B0DP24S289>) and installed Ubuntu minimal Linux into it. For installation, I had to use `nomodeset` boot option. I did not install any X system.

When it boots, I see "EFI stub" followed by some boot log lines. After a short run of those lines, screen turns off, then the backlight turns on, but the screen stays blank and no console login prompt is shown. If I blindly type login credentials and run commands - I can confirm they do run (I can connect to the machine via SSH).

If I specify `nomodeset` - the login prompt shows fine. I also tried using `sudo fbset -T 1 -d /dev/fb0 ~/jpeg_43-2.jpg` to test framebuffer display - it only works with `nomodeset`.

In dmesg, I see some interesting lines:

```
Reserving Intel graphics memory at [mem 0x700000000-0x7fffffff]
...
i915 0000:00:02.0: [drm] Unknown revid 0x06
```

Assignee
None

Labels
Community

Parent
None

Milestone
None

Dates
Start: None
Due: None

https://gitlab.freedesktop.org/drm/i915/kernel/-/work_items/13451

Hello? Hello-o?

 **Arun Raghavendra Murthy** @armurthy 6 months ago Reporter ⋮

[@tmistat](#) Any clue on what this error might lead to?

```
i915 0000:00:02.0: [drm] *ERROR* conflict detected with stolen region: [mem 0x70000000-0x7fffff
i915 0000:00:02.0: [drm] couldn't get memory information
```

 **Suresh** @suresh_kurmi 6 months ago Reporter ⋮

Cc: [@andi](#)

 **Andrey Pokhilko** @andrei.pokhilko 6 months ago Author ⋮

Are there any advices for my case? Any source code patch, or source code area in the driver that I should experiment with? I am willing to do coding help on this if it's simple enough...

 **Suresh** @suresh_kurmi 6 months ago Reporter ⋮

Cc: [@andi](#) [@tmistat](#)

Learned how to enable debug logging.

The unsupported firmware?

i915 0000:00:02.0: [drm] Unknown revision 0x06



...

i915 0000:00:02.0: [drm] Unknown revid 0x06

...

i915 0000:00:02.0: [drm] RC6 and powersaving disabled by BIOS

Reports at <https://linux-hardware.org/?id=pci:8086-3185-8086-2212>:

B0789 »	convertible	Medion / E3222 MD62450	<u>1</u>	 Manjaro 17....	works
60F4C »	all in one	Alfawise / T1	<u>2</u>	 Ubuntu 18.10	works
4D71D »	notebook	Koompi	<u>2</u>	 Arch	works



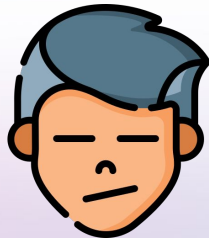

Would other OS work?

Other Linux Family:

- Different Kernel versions
- Fedora Workstation Live
- SystemRescueCD
- Puppy Linux

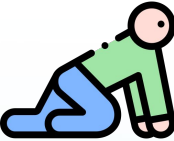

Non-Linux:

- Hiren's BootCD PE 
- ReactOS 
- MenuetOS 
- Haiku OS - 800x600 rotated 
- GhostBSD - worked! But no WiFi 

How did Windows work there?

- Attempt to install Windows hit some “missing driver” problem, stuck there
- Can I get the OS image from that liubinbin2023@126.com ? Yes and no.

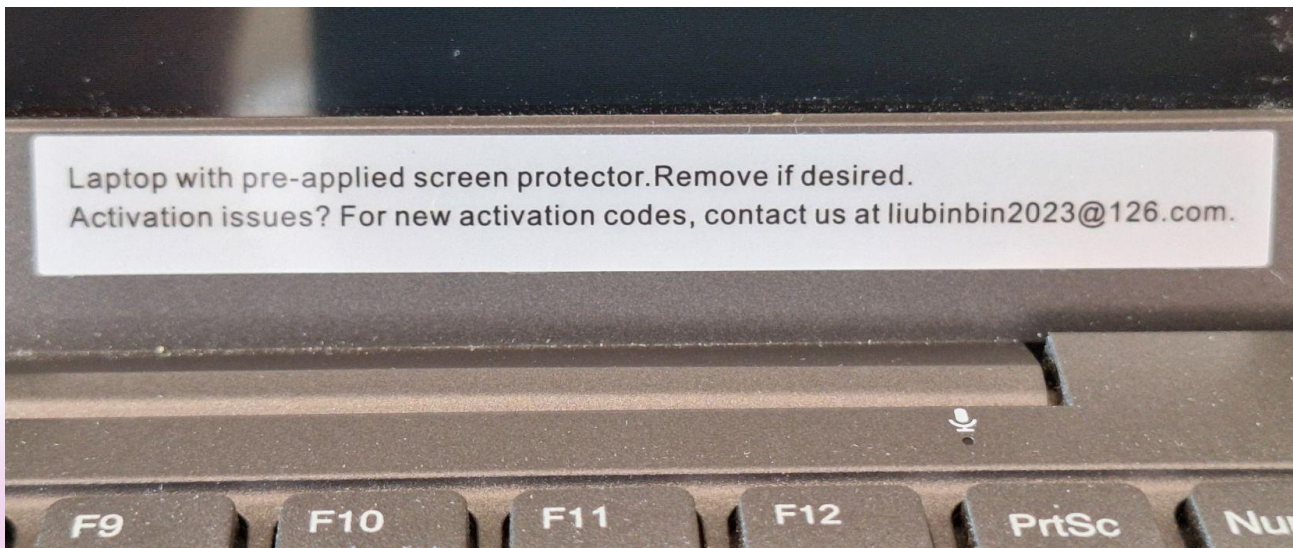

Linux HW Info: `dmidecode -t 2`

Handle 0x0002, DMI type 2, 15 bytes

Base Board Information

Type:	Motherboard
Manufacturer:	Default string
Product Name:	Default string
Version:	Default string
Serial Number:	Default string
Asset Tag:	Default string
Location In Chassis:	Default string

What is this hardware?

- BIOS [HL-BI-10.1-Y116GR670-034-B](#) 07/22/2024
- Image: [HL-JX-10.1-Y116GR670-034-A](#) (WIN11 22H2).zip
- What is there in the QR code on inside?

D2402016DB00011#[Y116GR670](#)-GN65B-#B

:(



Not Ready To Accept The Loss



Compiling kernel is easy

- Check out “drm-tip” <https://gitlab.freedesktop.org/drm/tip>
- Install tooling
- `make defconfig`
- `make menuconfig`
- `make -j$(nproc)`
- `sudo make modules_install install`

Make it into GRUB (prepare multiple options), beboot!

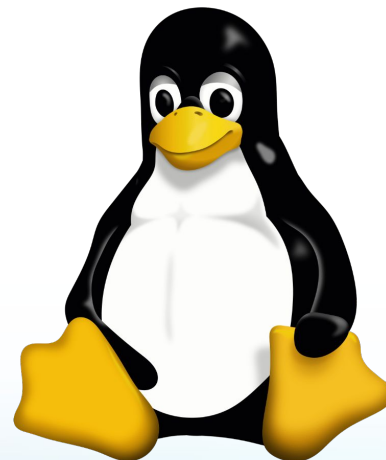

Experiment with different configurations

- `make olddefconfig` – to copy config from existing
- `make localmodconfig` – to try to remove the unused modules
- *Disable options to gradually minimize OS*
- Top-down narrowing the scope



Suddenly – it works!

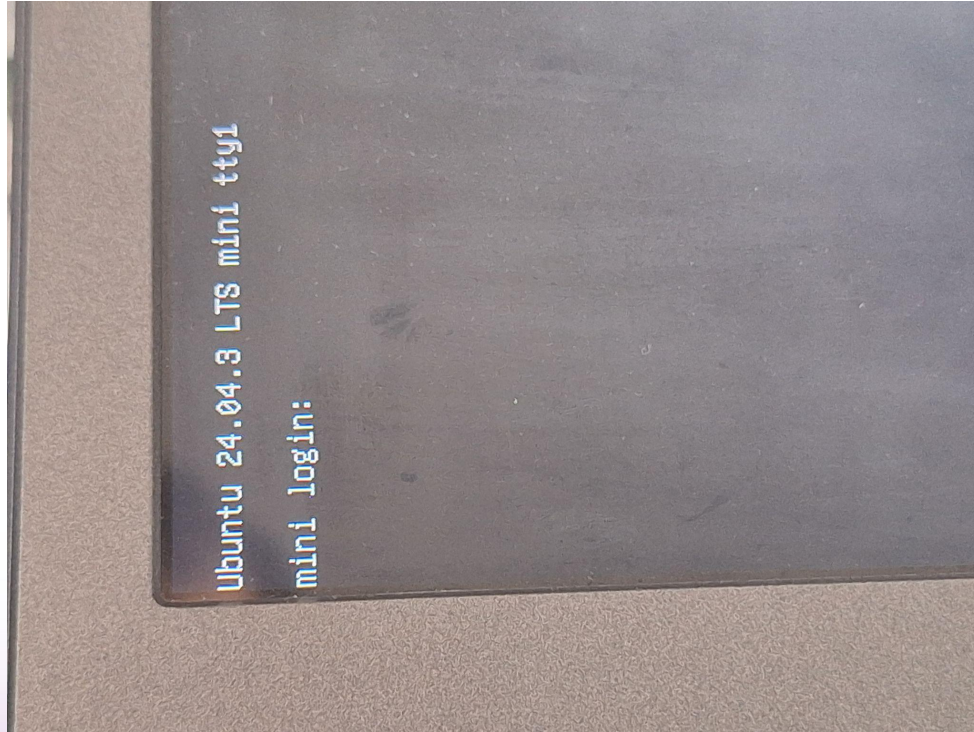

(but OS in quite weird state, a lot of functions are disabled)

Second take on compiling

- I know it's possible
- I know the key is in kernel options
- Let's go bottom-up, minimalistic

The Research Loop

- ``make allnoconfig`` – to start empty
- Add options one by one with ``make menuconfig``
- First make it bootable on [QEMU](#) emulator
- Then move onto actual hardware and continue
- [Automated snapshot](#) and diffs for config, dmesg, lsmmod, lspci, lsusb

Minimal bootable on QEMU

- 727 config options

(python script + [gephi](#) visualizer)

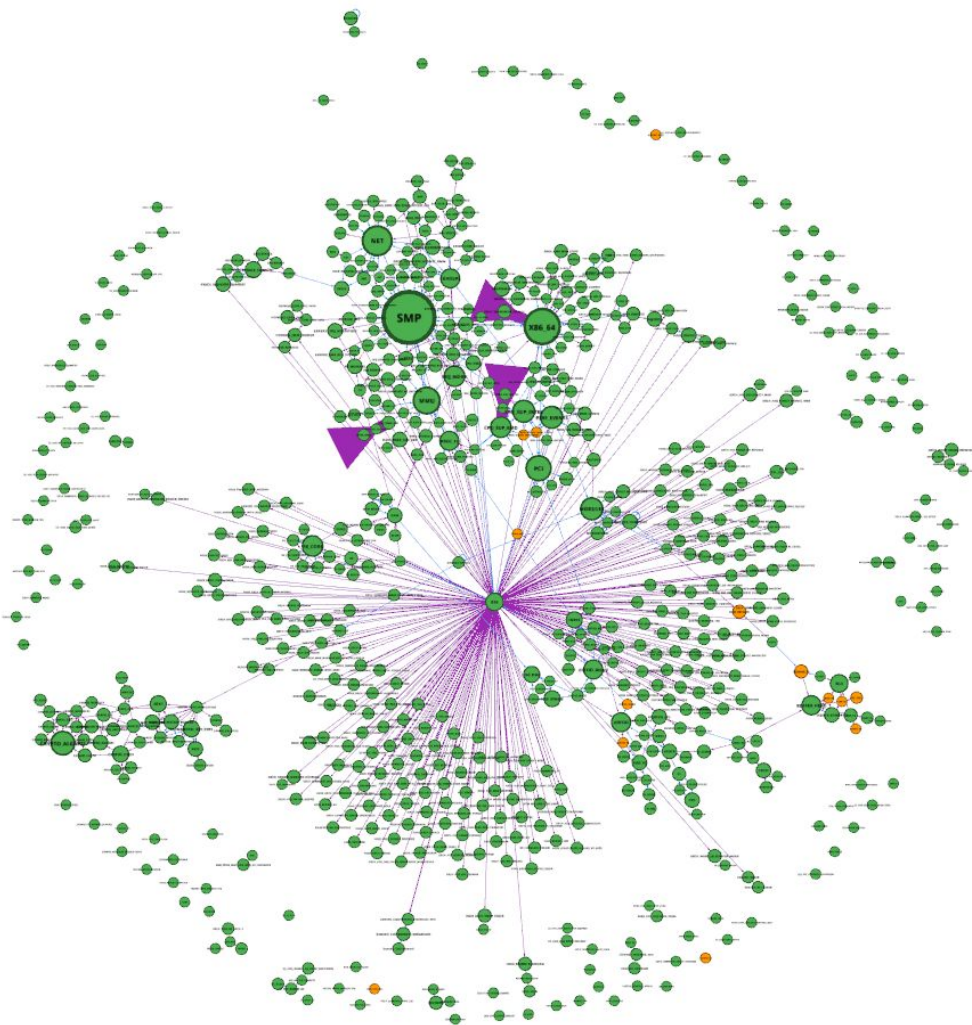

Overheating problem

- Each crash damages compile files unpredictably

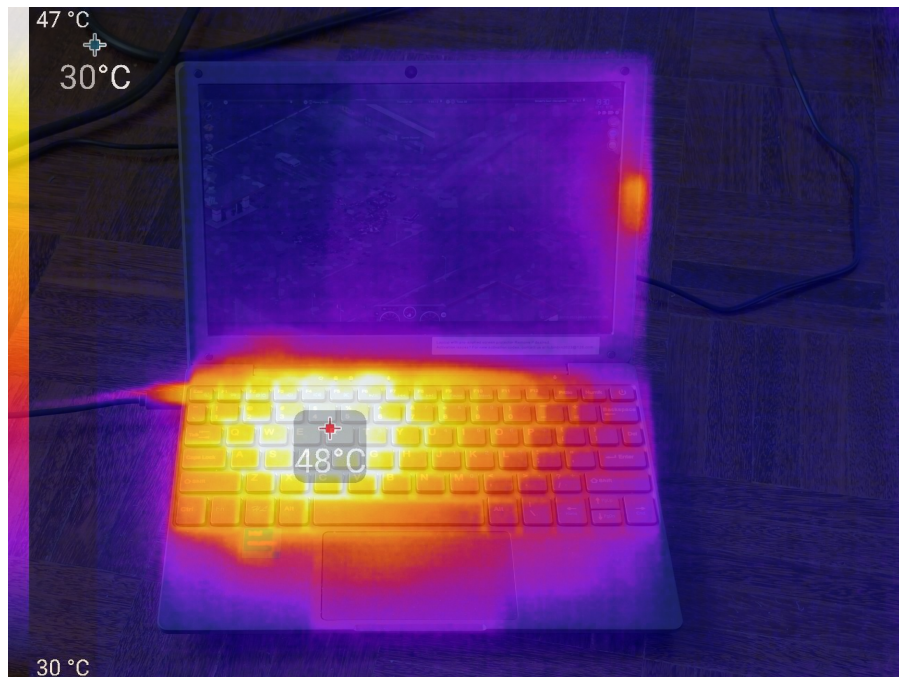
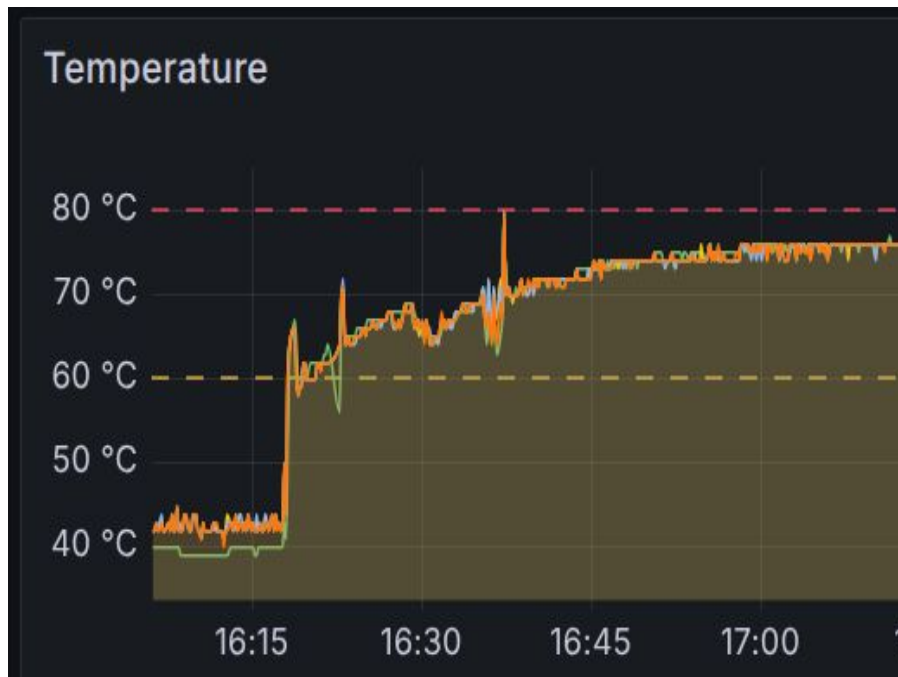

Minimal i915 enabled

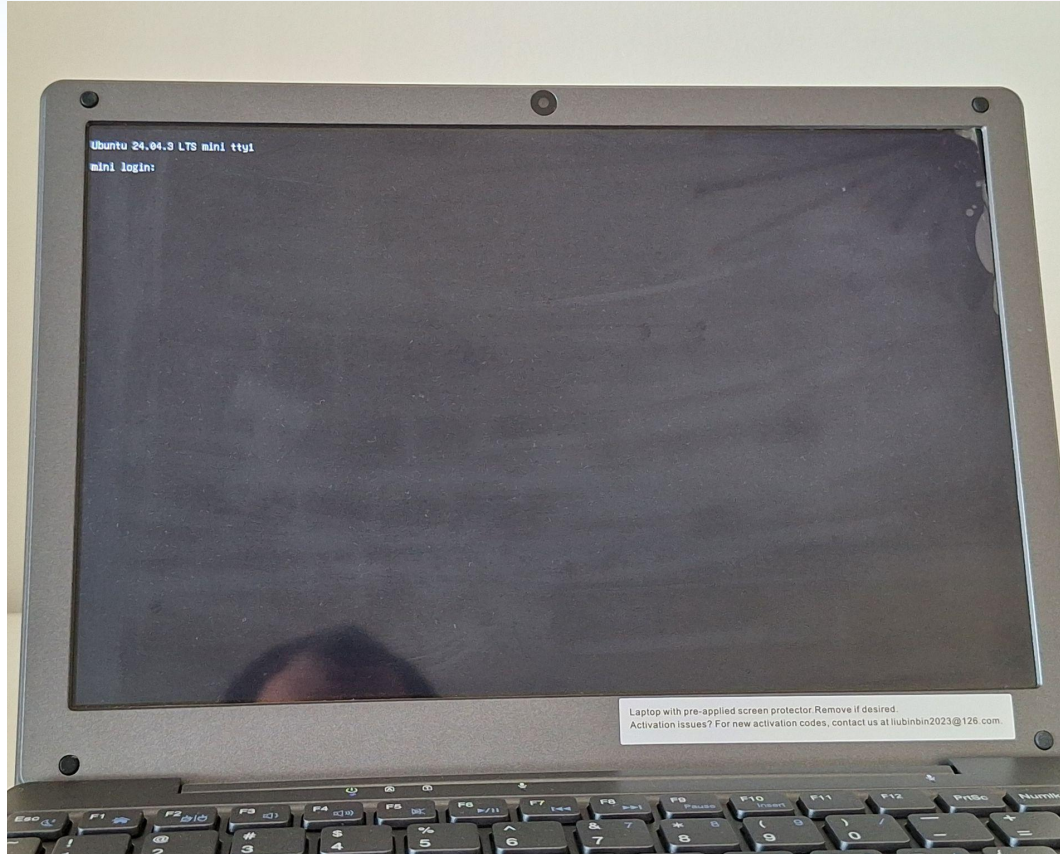

**A-ha
moment!**

Automated snapshots
have caught it!

PINCTRL_GEMINILAKE

- ...among Intel options
- 1964 config options enabled

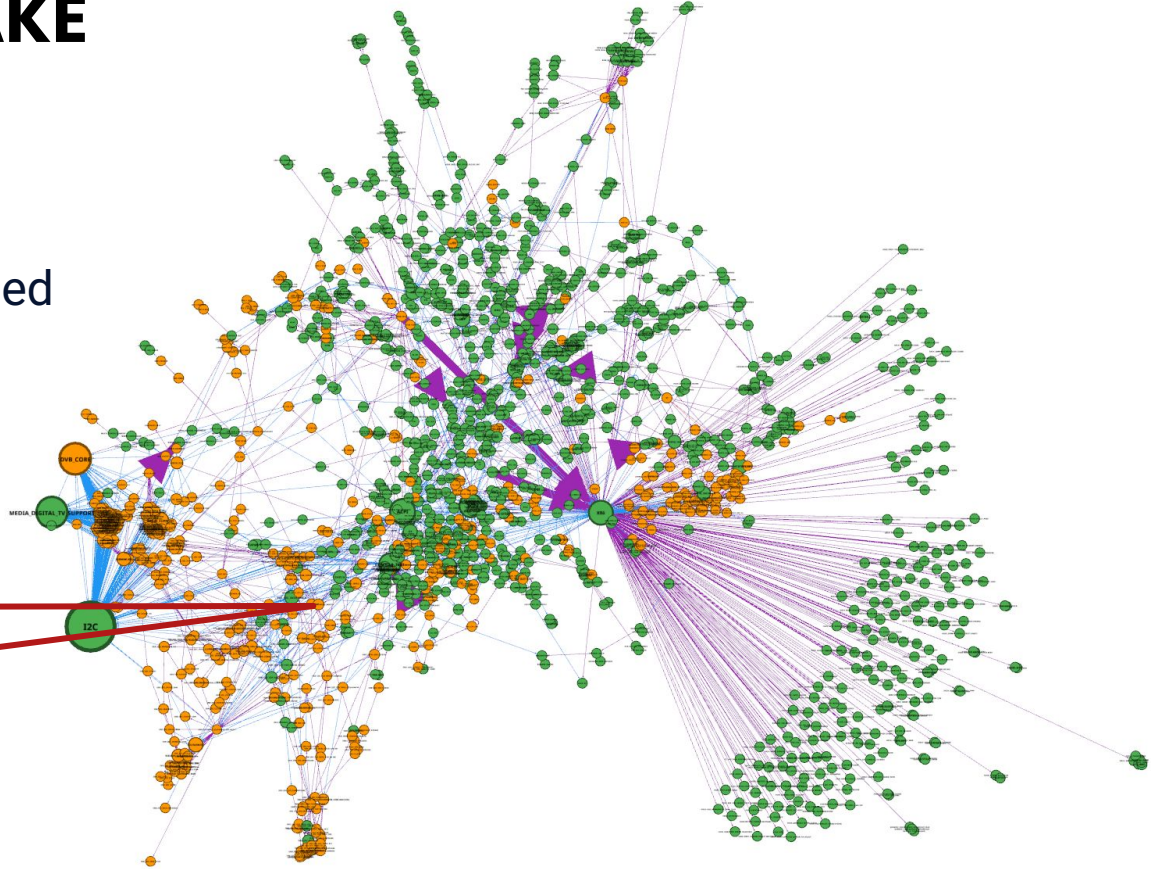
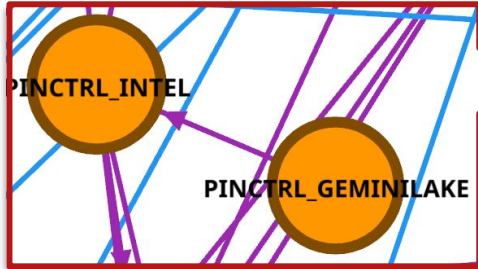

Kernel module `pinctrl_geminilake`

- Can we blacklist it and use stock kernel?

- Video works with stock kernel! 🎉

- Wait, what? (no sound! no touchpad!) 😞

What does PINCTRL do for i915?

Remember those lines?

```
i915 0000:00:02.0: [drm] *ERROR* GPIO index 6 request to set 1 failed (-EPROBE_DEFER)
```

```
i915 0000:00:02.0: [drm] *ERROR* GPIO index 6 request to set 0 failed (-EPROBE_DEFER)
```

```
i915 0000:00:02.0: [drm] *ERROR* GPIO index 6 request to set 1 failed (-EPROBE_DEFER)
```

MIPI Sequences

```
i915 0000:00:02.0: ... Starting MIPI sequence 7 - MIPI_SEQ_BACKLIGHT_OFF
i915 0000:00:02.0: ... Starting MIPI sequence 4 - MIPI_SEQ_DISPLAY_OFF
i915 0000:00:02.0: ... Starting MIPI sequence 5 - MIPI_SEQ_ASSERT_RESET
i915 0000:00:02.0: ... Starting MIPI sequence 11 - MIPI_SEQ_POWER_OFF
i915 0000:00:02.0: ... Starting MIPI sequence 10 - MIPI_SEQ_POWER_ON
```

```
i915 0000:00:02.0: ... Starting MIPI sequence 2 - MIPI_SEQ_INIT_OTP
i915 0000:00:02.0: [drm] *ERROR* GPIO index 6 request to set 1 failed (-EPROBE_DEFER)
i915 0000:00:02.0: [drm] *ERROR* GPIO index 6 request to set 0 failed (-EPROBE_DEFER)
i915 0000:00:02.0: [drm] *ERROR* GPIO index 6 request to set 1 failed (-EPROBE_DEFER)
```

```
i915 0000:00:02.0: ... Starting MIPI sequence 3 - MIPI_SEQ_DISPLAY_ON
i915 0000:00:02.0: ... Starting MIPI sequence 6 - MIPI_SEQ_BACKLIGHT_ON
```

VBT > i915 > GPIO > GPU

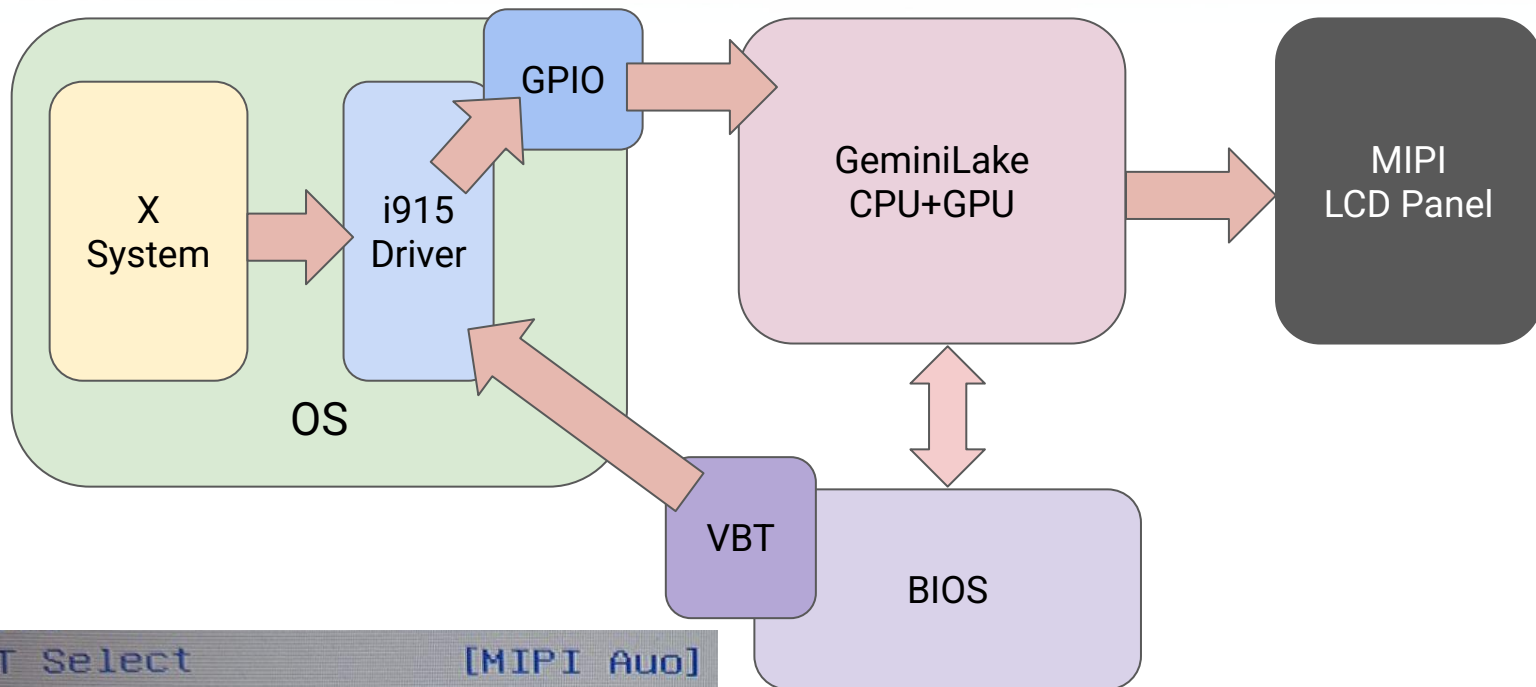

VBT Select

[MIPI AuO]

Video BIOS Table (VBT)

BDB block 53 (257 bytes) - MIPI sequence block:

Sequence block version v3

Panel 0 *

Sequence 2 - [MIPI_SEQ_INIT_OTP](#)

GPIO index 6, number 135, set 1 (0x01)

Delay: 10000 us

GPIO index 6, number 135, set 0 (0x00)

Delay: 30000 us

GPIO index 6, number 135, set 1 (0x01)

Delay: 100000 us

Sequence 6 - [MIPI_SEQ_BACKLIGHT_ON](#)

GPIO index 4, number 145, set 1 (0x01)

Delay: 2000 us

Sequence 7 - [MIPI_SEQ_BACKLIGHT_OFF](#)

GPIO index 4, number 145, set 0 (0x00)

Delay: 1000 us

pinctl_geminilake.c

```
PINCTRL_PIN(52, "PANEL0_VDDEN"),  
PINCTRL_PIN(53, "PANEL0_BKLTEN"),  
PINCTRL_PIN(54, "PANEL0_BKLTCTL"),  
...  
PINCTRL_PIN(59, "GPIO_135"),
```

- There is some translation of indexes done in `devm_gpiod_get_index()`
- ChatGPT gets me to ACPI tables
- It feels less and less productive...



Intel® Pentium® Silver and Intel® Celeron® Processors

Datasheet Volume 1 of 2

Revision 005

July 2021

Table 3-51. Northwest Community Mapping (TXE and Direct IRQ)

North Community (CSE and Direct IRQ Wake Wires)															
Pads						80									
Multiplex Out						Multiplex Select									
7			6			5		4	3			2		1	0
0	112	96	80	GPIO_140	64	HV_DDI0_DDC_SDA	48	PMU_SUS_CLK	32	FST_SPI_MOSI_IO0	16	SVID0_ALERT_B	0		
1	113	97	81	GPIO_141	65	HV_DDI0_DDC_SCL	49	SUS_STAT_B	33	FST_SPI_MISO_IO1	17	SVID0_DATA	1		
2	114	98	82	GPIO_142	66	HV_DDI1_DDC_SDA	50	LPSS_I2C5_SDA	34	FST_SPI_IO2	18	SVID0_CLK	2		
3	115	99	83	GPIO_143	67	HV_DDI1_DDC_SCL	51	LPSS_I2C5_SCL	35	FST_SPI_IO3	19	LPSS_SPI0_CLK	3		
4	116	100	84	GPIO_144	68	PANEL0_VDDEN	52	LPSS_I2C5_SDA	36	FST_SPI_CLK	20	LPSS_SPI0_FS0	4		
5	117	101	85	GPIO_145	69	PANEL0_BKLTEN	53	LPSS_I2C5_SCL	37	FST_SPI_CLK_FB	21	LPSS_SPI0_FS1	5		
6	118	102	86	GPIO_146	70	PANEL0_BKLTCTL	54	LPSS_I2C5_SDA	38	PMU_PLTRS_T_B	22	LPSS_SPI0_RXD	6		
7	119	103	87	LPC_ILB_SERIRQ	71	HV_DDI0_HPD	55	LPSS_I2C7_SCL	39	PMU_PWRB_TN_B	23	LPSS_SPI0_TXD	7		

GPIO index 6, number 135 - what are those?

- Mentioned like that in VBT and dmesg

- `pinctl_geminilake.c`: `-_(\ツ)_/`

- Intel® spec: `-_(\ツ)_/`

- There is some translation of indexes done in `devm_gpiod_get_index()`

Figure 3-43. Event Multiplex

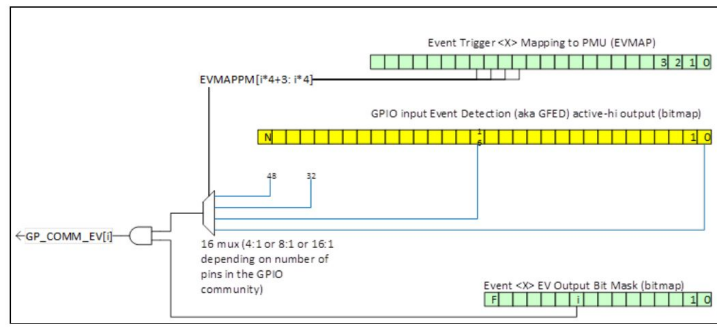

Patch for i915 in Kernel

```
--- a/drivers/gpu/drm/i915/display/intel_dsi_vbt.c
+++ b/drivers/gpu/drm/i915/display/intel_dsi_vbt.c
@@ -204,6 +204,13 @@ static void soc_gpio_set_value(
} else {
+  if (gpio_index == 6) {
+    return;
+  }
  gpio_desc = devm_gpiod_get_index(...);
```

Works for me!

- No suspend/resume
- Overheats sometimes
- I spent so much time
- I can live with result

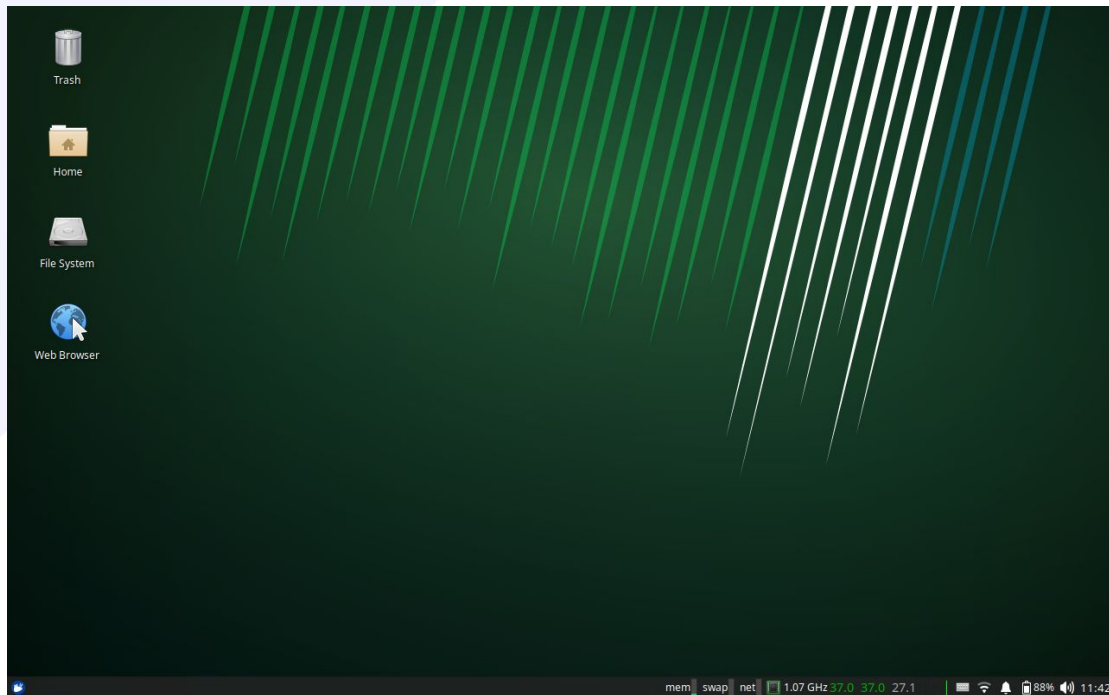

Key Takeaways (from 2025)

1. **Backup** before doing sharp turns
2. Searching “**unknown**” = iteratively remove
3. Searching “**known**” = iteratively add
4. **Linux** is the best piece of OSS software

Stock Ubuntu Kernel

~20K options

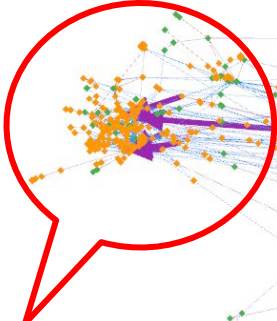

network stack

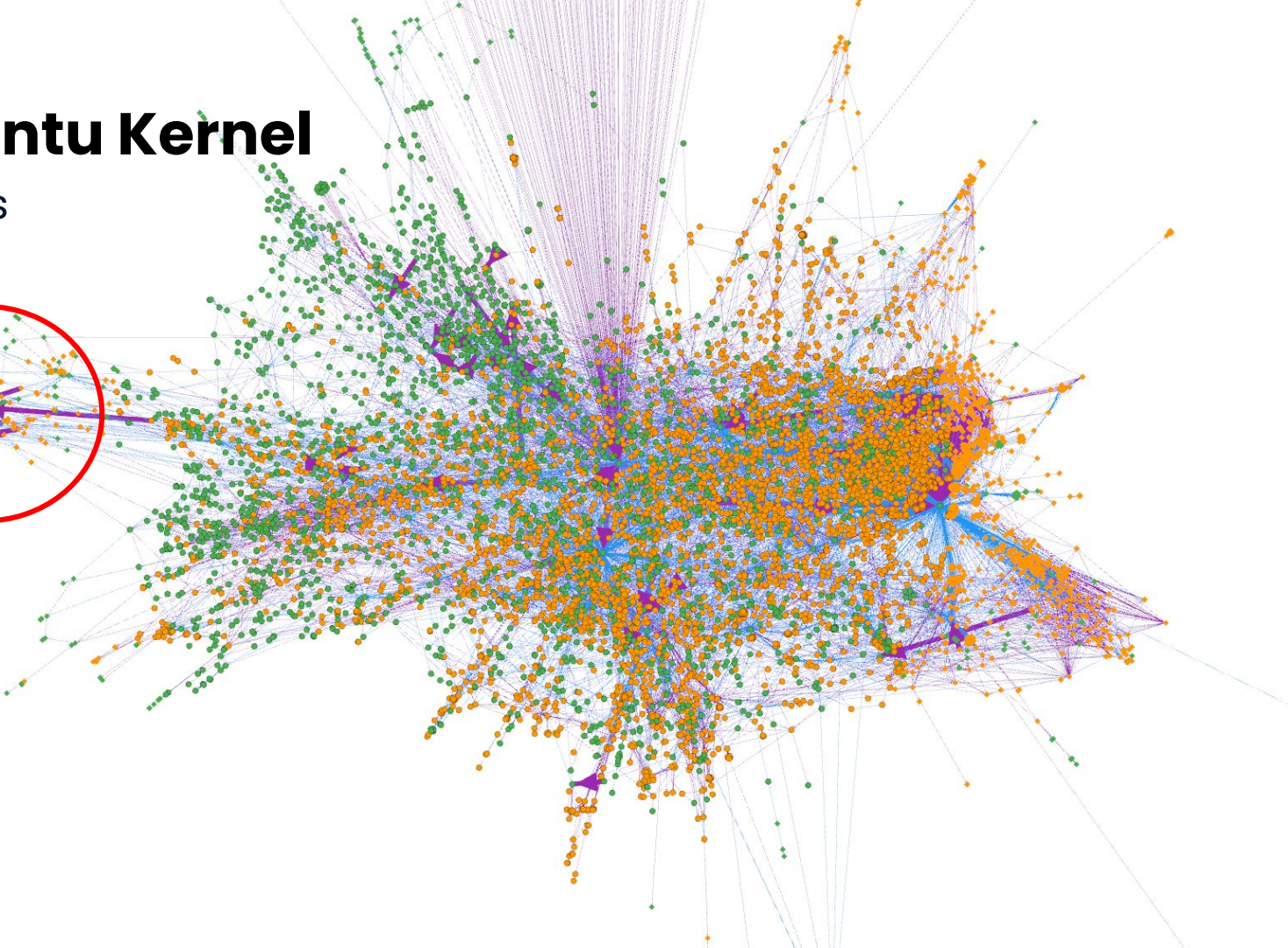

Bonus content: it's 2026 now

- ChatGPT is much smarter today
- I have Claude Code now
- I gave it my previous notes + laptop

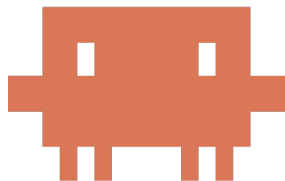

**Post-Agentive
Revision**

Final Iteration With Claude Code

- The problem is sufficiently **complex** even for Claude Code in 2026
- BIOS ACPI indeed translates **index 6** into **GPIO #59** (so what!)
- Sending **0** to **GPIO #59** causes the panel to never turn on
- The meaning of that operation is “**reset** internal registers of panel chip”
- Sending **1** is still needed for panel to start, explains loss of **suspend/resume**

VBT Patch

- Patch VBT firmware to send **1** instead of **0** for any mention of **pin #59**
- 2 bytes patched VBT file, ``i915.vbt_firmware=/patched.vbt`` in GRUB
- **Back to stock kernel, suspend/resume works!**
- No observable problems from that change
- Laptop producer to blame: bad VBT for this panel chip, not tested Linux

I would not learn so much if I had Claude Code from the start

Thank you!

Andrei Pokhilko

[undera](#) on GitHub